

PRODUCT DESCRIPTION

- Fixed output build in LED Driver.
- Constant Current LED Driver.
- Nominal Life-Time Upto 30,000 hr.
- 3/5-Years Warranty.
- CE (Certified).
- IS 15885 (Part 2/Sec 13).
- IS 16104.
- IEC 60950-1.
- IEC 61000-4-5.

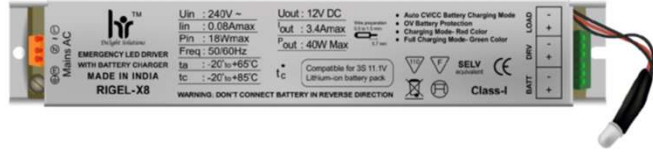

Input Characteristics

1	Voltage (Un)	240 Vac
2	Operating Voltage Range	100 ~300 Vac
3	Frequency (Hz)	50 / 60 Hz
4	Maximum Input Current	0.075A
5	Input Power (W)	18W
6	Inrush current Protection	Yes
7	Surge Withstanding Capacity	1.5 KV
8	Over Current Protection	Rated O/P Current (Tol: +/-3%)
9	Automatic Restart	300V
10	Driver Life	>30000Hrs

Mechanical Details

1	Weight	150gm.
2	Case Dimensions	
3	Length W/Mount	202.5mm
	Center to Center (CTC)	192mm
	Width	31.5mm
	Height	27mm
4	Case Material	Metal Box
5	Wiring Diagram	On Screen
6	Input / Output Terminals	Push Connector
7	Wires Length & Colors	
	Input (Yellow)	NA
	Output (Red & Black)	NA
8	Potting	NA

Output Characteristics

1	Output short circuit protection and Restart	Yes
2	Thermal Protection	Yes
3	No-Load Protection	Yes
4	Max Output Current	500MA (Tol: +/-3%)
5	Output Voltage	30-54V
6	Output Power (W)	16W max
7	Efficiency	88%

Key Features

1	Compact Design
2	High Voltage withstanding capacity
3	High Surge withstanding capacity
4	Long Life
5	High Durability
6	Automatic Restart after Safe Voltage Mode.
7	Charging and battery full indication

Environmental Operating Details

1	Minimum Starting Temperature	-30°C ... 75°C
2	Max. Ambient Temperature	-20°C ... to 65°C
3	Max. Case temperature (Tc)	75°C

Metal Box

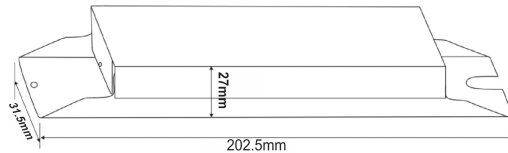

Bottom

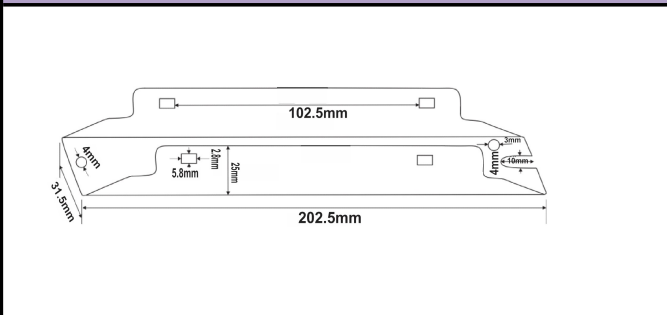

Top

